

SPEED CHECKER FOR HIGHWAYS



■ DIPANJAN BHATTACHARJEE

While driving on highways, motorists should not exceed the maximum speed limit permitted for their vehicle. However, accidents keep occurring due to speed violations since the drivers tend to ignore their speedometers.

This speed checker will come handy for the highway traffic police as it will not only provide a digital display in accordance with a vehicle's speed but also sound an alarm if the vehicle exceeds the permissible speed for the highway.

The system basically comprises two laser transmitter-LDR sensor pairs, which are installed on the highway 100 metres apart, with the transmitter and the LDR sensor of each pair on the opposite sides of the road. The installation of lasers and LDRs is shown in Fig. 1. The system displays the time taken by the vehicle in crossing this 100m distance from one pair to the other with a resolution of 0.01 second, from which the speed of the vehicle can be calculated as follows:

As per the above equation, for a

$$\text{Speed (kmph)} = \frac{\text{Distance}}{\text{Time}}$$

$$= \frac{0.1 \text{ km}}{(\text{Reading} \times 0.01) / 3600}$$

or,

$$\text{Reading (on display)} = \frac{36000}{\text{Speed}}$$

speed of 40 kmph the display will read 900 (or 9 seconds), and for a speed of 60 kmph the display will read 600 (or 6 seconds). Note that the LSB of the display equals 0.01 second and each succeeding digit is ten times the preceding

digit. You can similarly calculate the other readings (or time).

Circuit description

Fig. 2 shows the circuit of the speed checker. It has been designed assuming that the maximum permissible speed for highways is either 40 kmph or 60 kmph as per the traffic rule.

The circuit is built around five NE555 timer ICs (IC1 through IC5), four CD4026 counter ICs (IC6 through IC9) and four 7-segment displays (DIS1 through DIS4). IC1 through IC3 function as monostables, with IC1 serving

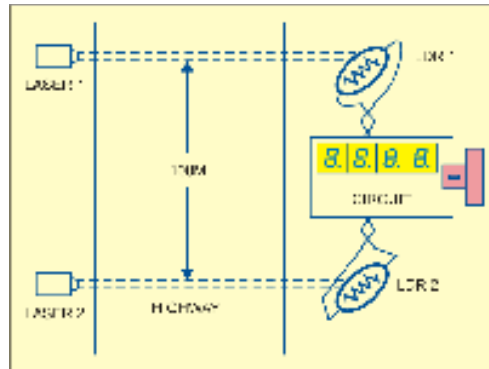

Fig. 1: Installation of lasers and LDRs on highway

as count-start mono, IC2 as count-stop mono and IC3 as speed-limit detector mono, controlled by IC1 and IC2 outputs. Bistable set-reset IC4 is also controlled by the outputs of IC1 and IC2 and it (IC4), in turn, controls switching on/off of the 100Hz (period = 0.01 second) astable timer IC5.

The time period of timer NE555 (IC1) count-start monostable multivibrator is adjusted using preset VR1 or VR2 and capacitor C1. For 40kmph limit the time period is set for 9 seconds using preset VR1, while for 60kmph limit the time period is set for 6 seconds using preset VR2. Slide switch S1 is used to select the time period as per the speed limit (40 kmph and 60 kmph, respectively).

PARTS LIST

Semiconductors:

- IC1-IC5 - NE555 timer
- IC6-IC9 - CD4026 decade counter/7-segment decoder
- IC10 - CD4011 NAND gate
- IC11 - 7812 12V regulator
- D1, D2 - 1N4148 switching diode
- D3-D6 - 1N4007 rectifier diode
- LED1 - Green LED
- LED2, LED3 - Red LED
- DIS1-DIS4 - LTS543 common-cathode, 7-segment display

Resistors (all 1/4-watt, ±5% carbon):

- R1, R4 - 100-kilo-ohm
- R2, R5, R6, R8, R10, R11, R14 - 10-kilo-ohm
- R3, R7, R13, R16-R19 - 470-ohm
- R9 - 470-kilo-ohm
- R12, R15 - 1-kilo-ohm
- VR1, VR2 - 100-kilo-ohm preset
- VR3 - 20-kilo-ohm preset

Capacitors:

- C1 - 100µF, 25V electrolytic
- C2, C4, C6, C8, C11 - 0.01µF ceramic disk
- C3, C13, C15 - 0.1µF ceramic disk
- C5 - 10µF, 25V electrolytic
- C7 - 0.47µF, 25V electrolytic
- C9 - 0.2µF ceramic disk
- C10 - 1µF, 25V electrolytic
- C12 - 47µF, 25V electrolytic
- C14 - 1000µF, 35V electrolytic

Miscellaneous:

- X1 - 230V AC primary to 0-15V, 500mA secondary transformer
- PZ1 - Piezobuzzer
- LDR1, LDR2 - LDR
- S1, S2 - Push-to-on switch
- S3 - On/Off switch
- Pointed laser light

The junction of LDR1 and resistor R1 is coupled to pin 2 of IC1.

Normally, light from the laser keeps falling on the LDR sensor continuously and thus the LDR offers a low resistance and pin 2 of IC1 is high. Whenever light falling on the LDR is interrupted by any vehicle, the LDR resistance goes high and hence pin 2 of IC1 goes low to trigger the monostable. As a result, output pin 3 goes high for the preset period (9 or 6 seconds) and LED1 glows to indicate it. Reset pin 4 is controlled by the output of NAND

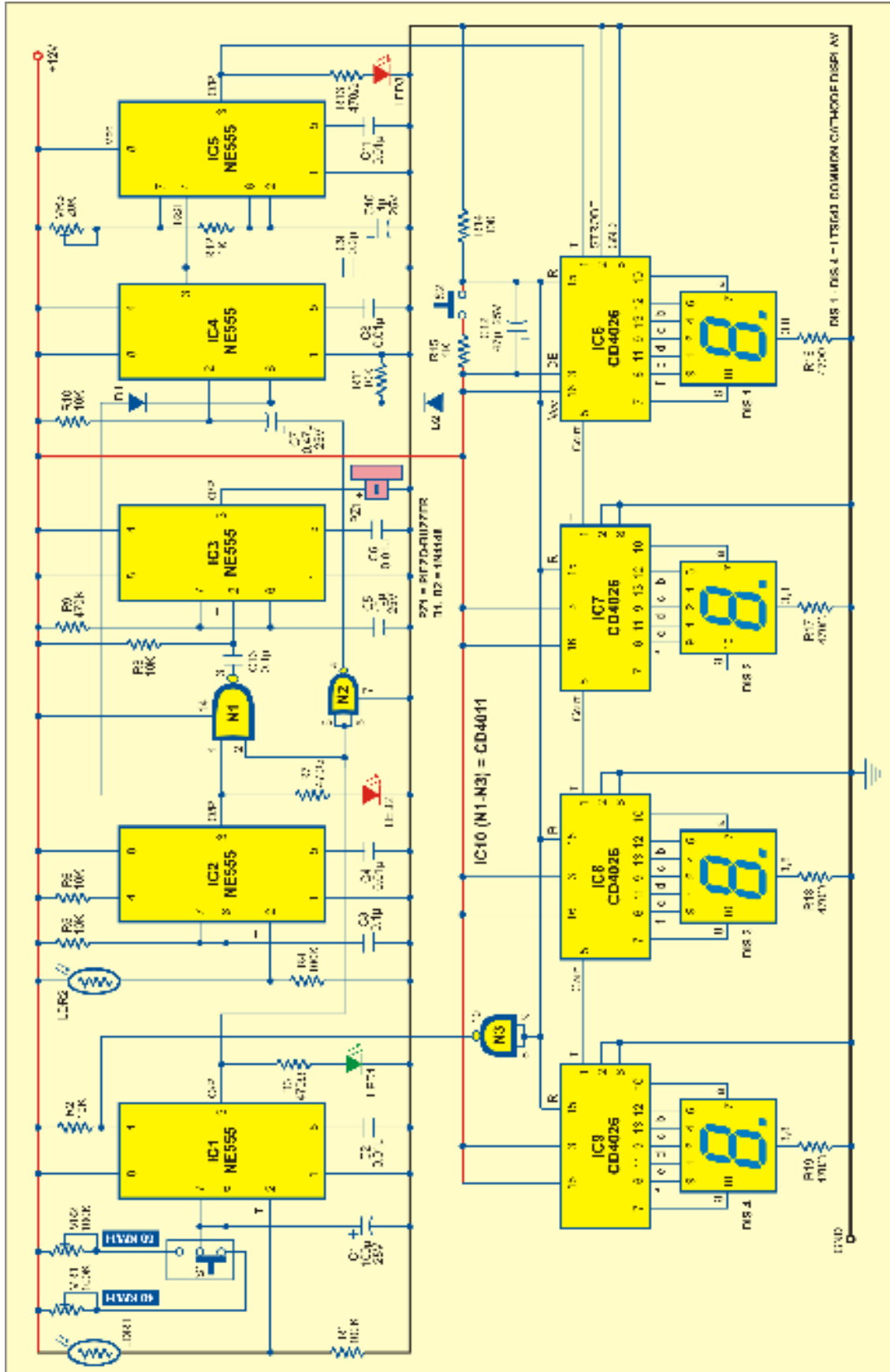

Fig. 2: Circuit of speed checker for highway

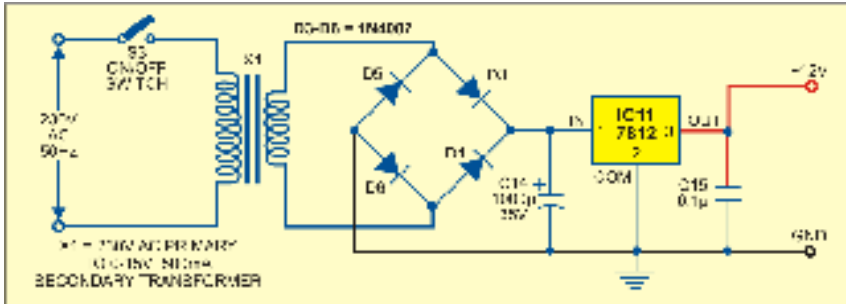

Fig. 3: Power supply

generator IC5. IC5 can also be reset via diode D2 at power-on as well as when reset switch S2 is pressed.

IC5 is configured as an astable multivibrator whose time period is decided by preset VR3, resistor R12 and capacitor C10. Using preset VR1, the frequency of the astable multivibrator is set as 100 Hz. The output of IC5 is fed to clock pin 1 of decade counter/7-segment decoder IC6 CD4026.

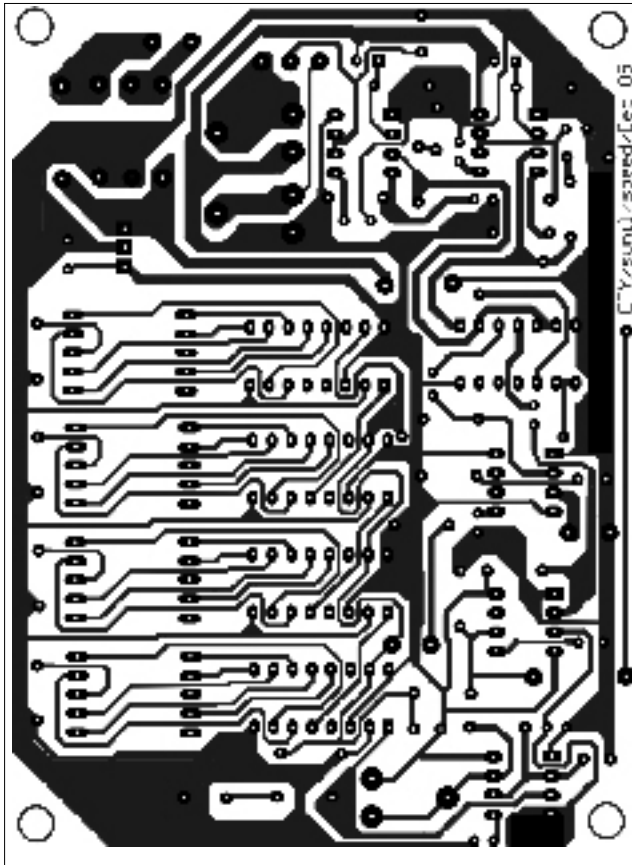

Fig. 4: Actual-size, single-side PCB layout for the speed checker

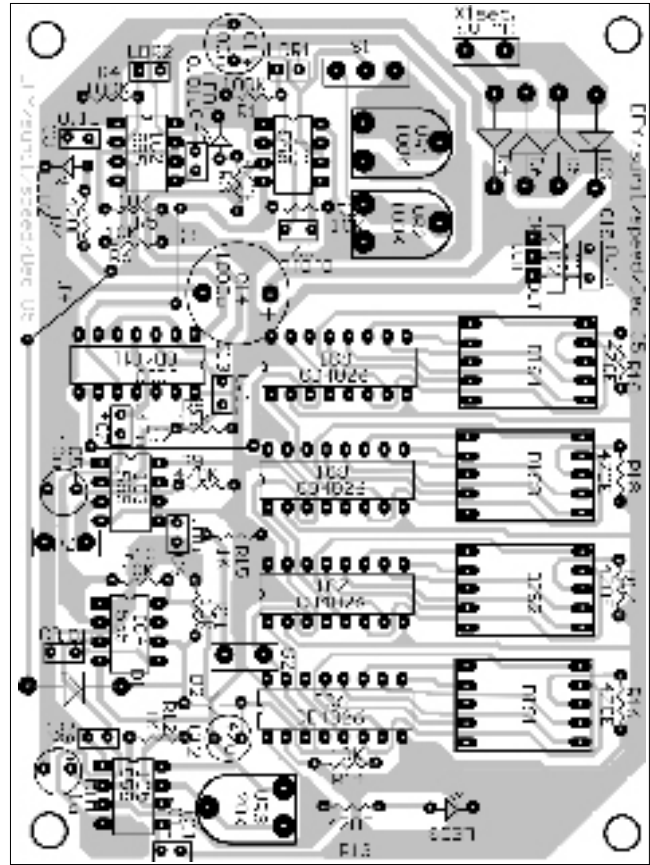

Fig. 5: Component layout for the PCB

gate N3 at power-on or whenever reset switch S2 is pushed.

For IC2, the monostable is triggered in the same way as IC1 when the vehicle intersects the laser beam incident on LDR2 to generate a small pulse for stopping the count and for use in the speed detection. LED2 glows for the duration for which pin 3 of IC2 is high.

The outputs of IC1 and IC2 are fed to input pins 2 and 1 of NAND gate N1, respectively. When the outputs of IC1 and IC2 go high simultaneously (meaning that the vehicle has crossed the preset speed limit), output pin 3 of

gate N1 goes low to trigger monostable timer IC3. The output of IC3 is used for driving piezobuzzer PZ1, which alerts the operator of speed-limit violation. Resistor R9 and capacitor C5 decide the time period for which the piezobuzzer sounds.

The output of IC1 triggers the bistable (IC4) through gate N2 at the leading edge of the count-start pulse. When pin 2 of IC4 goes low, the high output at its pin 3 enables astable clock generator IC5. Since the count-stop pulse output of IC2 is connected to pin 6 of IC4 via diode D1, it resets clock

IC CD4026 is a 5-stage Johnson decade counter and an output decoder that converts the Johnson code into a 7-segment decoded output for driving DIS1 display. The counter advances by one count at the positive clock signal transition.

The carry-out (Cout) signal from CD4026 provides one clock after every ten clock inputs to clock the succeeding decade counter in a multidecade counting chain. This is achieved by connecting pin 5 of each CD4026 to pin 1 of the next CD4026.

A high reset signal clears the de-

cade counter to its zero count. Pressing switch S2 provides a reset signal to pin 15 of all CD4026 ICs and also IC1 and IC4. Capacitor C12 and resistor R14 generate the power-on-reset signal.

The seven decoded outputs 'a' through 'g' of CD4026s illuminate the proper segment of the 7-segment displays (DIS1 through DIS4) used for representing the decimal digits '0' through '9.' Resistors R16 through R19 limit the current across DIS1 through DIS4, respectively.

Fig. 3 shows the circuit of the power supply. The AC mains is stepped down by transformer X1 to deliver the secondary output of 15 volts, 500 mA. The transformer output is rectified by a bridge rectifier comprising diodes D3 through D6, filtered by capacitor C14 and regulated by IC11 to provide regulated 12V supply. Capacitor C15 bypasses any ripple in the regulated output. Switch S3 is used as the 'on'/'off' switch. In mobile application of the circuit, where mains 230V AC is not available, it is advisable to use an exter-

nal 12V battery. For activating the lasers used in conjunction with LDR1 and LDR2, separate batteries may be used.

Construction and working

Assemble the circuit on a PCB. An actual-size, single-side PCB layout for the speed checker is shown in Fig. 4 and its component layout in Fig. 5.

Before operation, using a multimeter check whether the power supply output is correct. If yes, apply power supply to the circuit by flipping switch S3 to 'on.' In the circuit, use long wires for connecting the two LDRs, so that you can take them out of the PCB and install on one side of the highway, 100 metres apart. Install the two laser transmitters (such as laser torches) on the other side of the highway exactly opposite to the LDRs such that laser light falls directly on the LDRs. Reset the circuit by pressing switch S2, so the display shows '0000.' Using switch S1, select the speed limit (say, 60 kmph) for the highway. When any vehicle crosses the first laser light, LDR1 will trigger

IC1. The output of IC1 goes high for the time set to cross 100 metres with the selected speed (60 kmph) and LED1 glows during for period. When the vehicle crosses the second laser light, the output of IC2 goes high and LED2 glows for this period.

Piezobuzzer PZ1 sounds an alarm if the vehicle crosses the distance between the laser set-ups at more than the selected speed (lesser period than preset period). The counter starts counting when the first laser beam is intercepted and stops when the second laser beam is intercepted. The time taken by the vehicle to cross both the laser beams is displayed on the 7-segment display. For 60kmph speed setting, with timer frequency set at 100 Hz, if the display count is less than '600,' it means that the vehicle has crossed the speed limit (and simultaneously the buzzer sounds). Reset the circuit for monitoring the speed of the next vehicle.

Note. This speed checker can check the speed of only one vehicle at a time. ●