

MULTI-MELODY GENERATOR WITH INSTRUMENTAL EFFECT

■ EFY LAB

This melody generator can generate various English and Hindi tunes as also instrumental effects. Various modes of melodies can be selected through DIP switches.

to the programmed data. Its inbuilt preamplifier provides a simple interface to the driver circuit. The IC can be replaced with other UM348XXX series, WR630173 or WE4822 melody generator ICs. A WR630173 preprogrammed as Hindi melody genera-

terminal through which instrumental effects are produced. The preamplifier outputs are available at pins 10 and 11, which are fed to loudspeaker-driver transistors T1 (SK100) and T2 (SL100), respectively.

When you switch on the circuit by closing switch S1, LED1 glows. If DIP switches S3 and S5 are closed and S4 open, pressing input switch S2 will generate a melody tone from the loudspeaker. Vary VR1 to adjust its volume. Pressing S2 again will generate a new melody tone. If switches S3 and S4 are opened while S5 is closed, the same tone keeps repeating for every pressing of S2. The positions of DIP switches and the various modes of melodies are summarised in the table.

When switch S5 is open, it will generate an instrumental effect from the loudspeaker. This effect is produced by the enveloping circuit consisting of capacitor C1 and resistor R2 connected to pin 7 of IC1. In fact, by hit and trial you can choose the values of these components as per your taste by listening to the output sound. Only C1 or R2 or its parallel combination can be used to generate a distinct instrumental effect. To select any of these options, two jumper terminals J1 and J2 are provided in the circuit at C1 and R2, respectively. For example, if you want to use only C1, you can join J1 terminals using hookup wire or jumper cap and keep J2 open. The repetition of the musical effect depends on the status of switches S3 and S4.

The oscillation frequency is produced by the resistor and capacitor connected at pins 14 and 13 of IC1. This frequency is used as a time base for the tone, rhythm and tempo generators. The quality of the melody tones depends on this frequency. Resistor R6 (100-kilo-ohm) connected to pin 15 makes the circuit insensitive to variations in the power supply. ●

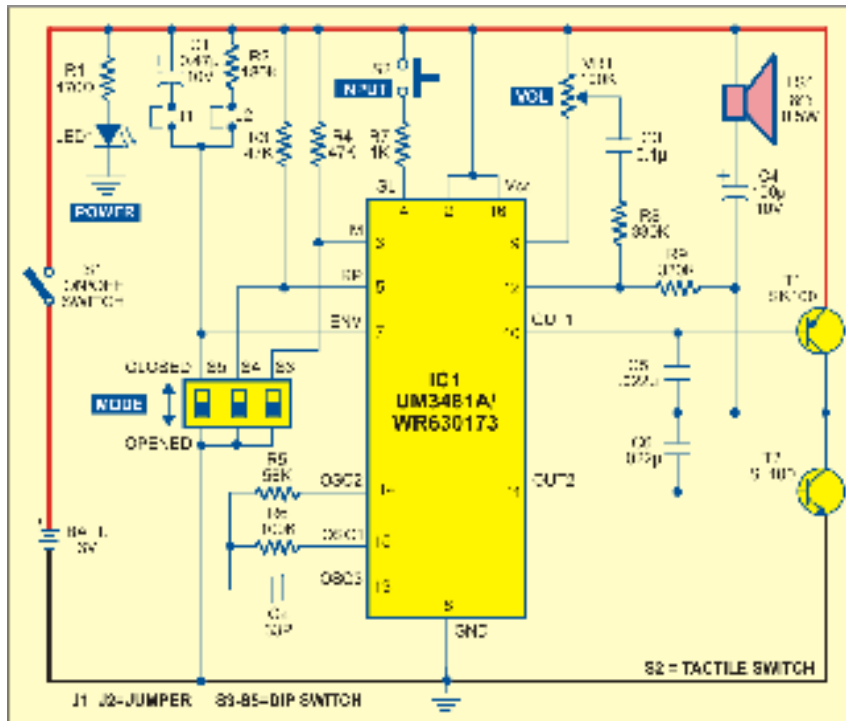

Positions of DIP Switches for Various Modes

S3	S4	S5	Mode of tone output
Opened	Opened	Closed	The same tone keeps repeating. Press S2 for the next tone.
Opened	Closed	Closed	Play a new tone for every pressing of S2.
Closed	Opened	Closed	Play all the tones one by one and then repeat the cycle without S2 input.
Closed	Closed	Closed	Play all the tones and stop (no repetition).

Other advantages are high volume and volume control.

IC UM3481A is a 16-pin multi-instrument melody generator. It is a mask-ROM-programmed IC designed to play the melody according

to the programmed data. Its inbuilt preamplifier provides a simple interface to the driver circuit. Various modes of operation are selected through DIP switches S3, S4 and S5 connected to pins 3, 5 and 7 of IC1, respectively. Pin 7 is the envelope circuit

input-select switch for producing different tones in the loudspeaker. Various modes of operation are selected through DIP switches S3, S4 and S5 connected to pins 3, 5 and 7 of IC1, respectively. Pin 7 is the envelope circuit

can be used here. There are 16 tunes stored in WR630173 including *mera joota hai japani, mera naam chin chin chu, hare rama hare krishna, raghu pati raghav raja ram and ramaiya vasta vaiya.*