

LOW-COST ENERGY METER USING ADE7757



■ SUNIL KUMAR

Electromechanical energy meters have been the standard for metering the electricity since billing began. But these are now being gradually replaced by digital signal processor (DSP)-based energy meters, or kilowatt-hour (kWh) meters.

More accurate energy measurement and additional features are in fact accelerating the adoption of DSP-based meters. Their additional features include power quality monitoring, recording of current/voltage peaks and voltage sags, registering of digitised waveforms for analysis, and monitoring of active and reactive power and power factor information.

Some metering chips have a serial port interface (SPI) that can be used for establishing communication with a microcontroller-based mobile gadget to control the functionality of the metering chip, perform calibration and transfer the recorded data. Analog Devices offers an extensive range of metering ICs to serve various needs.

Here's an energy meter using Analog Devices' ADE7757 chip for single-phase, 2-wire (phase and neutral) systems used in households. IC ADE7757 is a low-cost, single-chip solution for

electrical energy measurement.

The meter is designed based on Analog Devices' application notes. Its salient features are:

1. It can read up to 999,999 units (kWh) with a resolution of 0.01 unit.
2. It is designed for nominal 230V AC, 45-65 Hz and maximum line current of 30 amps. (The metering IC can be used with a maximum current of 120 amps.)
3. The dynamic range is 400 (i.e., 75 mA to 30A).
4. The meter count is 100 impulses/kWh, i.e., 100 impulses will be required to register one unit.
5. The accuracy level is better than Class 2 defined in international standard IEC1036 (1996-09). The maximum error limit for various current values as per this standard is shown in Table I.

IC ADE7757

Fig. 1 shows the functional block diagram of metering IC ADE7757. It is available in 16-lead SOIC narrow-body package. In our PCB layout, it is to be soldered on the conductor side of the PCB. The IC has an on-chip oscillator, so it requires no external crystal or resonator, thus reducing the overall cost of building a watt-hour meter. It

operates off a 5V power supply.

In operation, the chip directly interfaces with a shunt resistor (used as the current sensor) and AC analogue voltage sensing input. It has two analogue input channels designated as V1

PARTS LIST

Semiconductors:

IC1	- ADE7757 metering IC
IC2, IC5	- 7805 5V regulator
IC3, IC4	- MCT2E optocoupler
IC6, IC7	- MM74926 7-segment driver
T1-T8	- BC548 npn transistor
D1-D3	- 1N4007 rectifier diode
ZD1	- 15V, 1W zener diode
BR1	- W04M bridge rectifier
DIS1- DIS8	- LTS543 common cathode, 7-segment display
LED1	- Red LED

Resistors (all 1/4-watt, ±5% carbon, unless mentioned otherwise):

R1, R3, R7,	
R8	- 500-ohm
R2	- 6.2-kilo-ohm
R4	- 470-ohm
R5, R6	- 680-ohm
R9	- 350-micro-ohm (shunt)
R10	- 1.8-mega-ohm
R11	- 2.2-kilo-ohm
R13	- 470-ohm, 1W
R14	- 1-kilo-ohm
R12, R15- R28	- 220-ohm
VR1	- 470-kilo-ohm trimpot

Capacitors:

C1, C3, C7,	
C8-C10	- 0.1µF ceramic disk
C2, C6	- 10µF, 25V electrolytic
C4, C5, C11,	
C12	- 0.068µF ceramic disk
C13	- 0.47µF, 630V polyester
C14	- 470µF, 35V electrolytic
C15	- 1000µF, 16V electrolytic

Miscellaneous:

L1, L2	- Ferrite bead inductor
Battery	- 4.5V rechargeable battery
X1	- 230V AC primary to 7.5V, 500mA secondary transformer

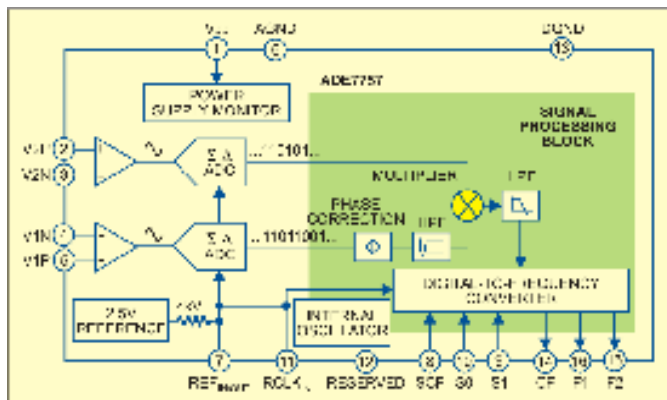

Fig. 1: Functional block diagram of IC ADE7757

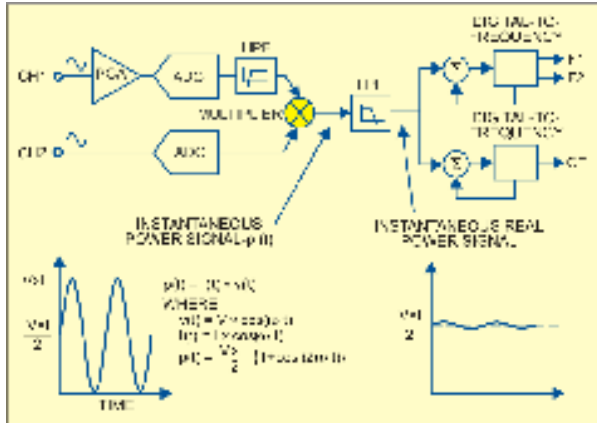

Fig. 2: Block diagram for signal processing along with the waveforms at the output of the multiplier and the low-pass filter (LPF)

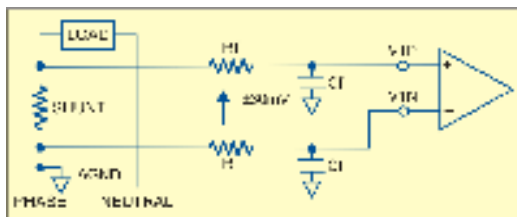

Fig. 3: Typical mains current sampling

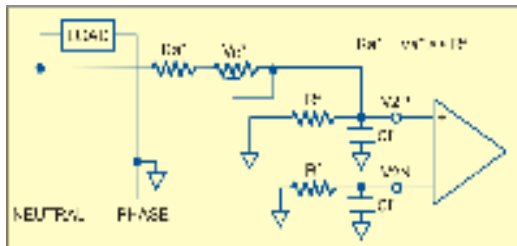

Fig. 4: Typical mains voltage sampling

TABLE I
Accuracy Requirements

Current value ¹	PF ²	Percentage error limits ³	
		Class 1	Class 2
0.05 lb < I < 0.1 lb	1	±1.5%	±2.5%
0.1 lb < I < I _{MAX}	1	±1.0%	±2.0%
0.1 lb < I < 0.2 lb	0.5 lag	±1.5%	±2.5%
	0.8 lead	±1.5%	
0.2 lb < I < I _{MAX}	0.5 lag	±1.0%	±2.0%
	0.8 lead	±1.0%	

Notes. 1. The current ranges for the specified accuracy are expressed in terms of the basic current (lb), which is defined as the value of the current in accordance with which the relevant performance of a direct connection meter is fixed. I_{MAX} is the maximum current at which the accuracy is maintained. At these frequencies we have taken the value of basic current lb as 5 amp.

2. Power factor (PF) gives the phase relationship between the fundamental voltage (45 to 65 Hz) and current waveforms. Here, it can be simply defined as PF = cos φ, where φ is the phase angle between the pure sinusoidal current and the voltage.

3. The percentage error =

$$\frac{(\text{Energy registered by the meter} - \text{True energy}) \times 100}{\text{True energy}}$$

a resistor divider, is connected between pins V2P and V2N.

IC ADE7757 also has a reference circuit and a fixed DSP function for calculation of the real power. A highly stable oscillator integrated into the chip provides the necessary clock for the chip. IC ADE7757 supplies the average real-power information on the F1 and

F2 low-frequency outputs. These outputs may be used to directly drive a stepper motor-based electromechanical counter or any other suitable counter.

IC ADE7757 also provides a high-frequency output at the calibration frequency (CF) pin for a selected meter constant (here, it is 3200 impulses/kWh). This high-frequency output provides instantaneous real-power information, which is used to speed up the calibration process. It also provides a means for quickly verifying the meter's functionality and accuracy in a production environment.

Theory of operation

The two analogue-to-digital converters (ADCs) used in the chip digitise the output of current and voltage sensors. The ADCs are 16-bit, sigma-delta type with an oversampling rate of 450 kHz. These work with oversampling so that the bandwidth of the input signal is much less than fs/2, where 'fs' is the sampling frequency. In its most basic form, the sigma-delta converter contains a one-bit ADC and DAC. It produces a higher-resolution digital word output by averaging several one-bit samples.

The real power is derived from the instantaneous power

signal. The instantaneous power signal is achieved by a direct multiplication of the current and voltage signals. In order to extract the real power component (referred to as the DC component), the instantaneous power signal is low-pass filtered. This scheme correctly calculates the real power for sinusoidal current and voltage waveforms at all power factors. All the signal processing is carried out in the digital domain for superior stability over temperature and time.

Fig. 2 shows the block diagram for signal processing along with the waveforms at the output of the multiplier and after the low-pass filter (LPF). It is observed that this method of extracting the real power information holds good even when the current is not in phase with the voltage. The real power component (DC component) of the instantaneous power for sinusoidal voltage/current waveforms with a power factor of 0.5 (current lagging the voltage by 60°) is:

$$\frac{V \times I}{2} \times \cos 60^\circ$$

The real power calculation holds good even for non-sinusoidal current and voltage waveforms.

Mains current sampling (channel V1). The voltage output from the current sensor (proportional to the load current) is connected to channel V1 of IC ADE7757, which is a fully differential voltage input. The V1P input is positive with respect to V1N. The maximum peak differential signal on channel V1 should be less than ±30 mV (i.e., 21mV rms for a pure sinusoidal signal) with reference to analogue ground (AGND) for the specified operation. Typical sampling connections are shown in Fig. 3.

Mains voltage sampling (channel V2). The output of the line voltage sensor is connected to IC ADE7757 at this analogue input. Channel V2, like channel V1, is a fully differential-voltage input channel with maximum peak differential signal of ±165 mV referenced to analogue ground (AGND). Typical connections for mains voltage sampling channel V2 are shown in Fig. 4. It is quite convenient to adjust the

ratios of R_a and V_R for adjusting the gain of the meter.

Phase matching between channels.

It is important that the relative phase difference between voltage and current waveforms at the inputs of V1 and V2 channels is not disturbed since any phase mismatch between channels will translate into significant measurement error at low power factors. IC ADE7757 is internally phase-matched over the frequency range of 40 Hz to 1 kHz between the two channels, which ensures that the relative phase relations of the two channels are maintained throughout the useful range of frequencies.

Power supply monitor. The on-chip power supply monitor of IC ADE7757 continuously monitors the power supply (V_{DD}). If the supply is less than 4V, IC ADE7757 is reset. This ensures proper device operation at power-up and power-down. The power supply monitor has built-in hysteresis and filtering that provides a high degree of immunity to false triggering due to noisy supply.

Transfer function. The transfer function refers to the relation between the true power into the load and its representation in terms of the equivalent frequency at F1 and F2 output points. The transfer function of IC ADE7757 is quite linear, and as such, a one-point calibration (at I_b) at unity power factor is all that is needed to calibrate the meter. If precautions are taken at the design stage, no calibration is necessary at power factors as low as 0.5 (i.e., phase difference of 60°).

The output frequency or pulse rate is related to the input voltage signals as follows:

where Freq is the output frequency

$$\text{Freq} = \frac{515.84 \times V1_{\text{rms}} \times V2_{\text{rms}} \times F_{1-4}}{V_{\text{ref}}^2}$$

on F1 and F2 (Hz), $V1_{\text{rms}}$ is the differential rms voltage signal on channel V1 (volts), $V2_{\text{rms}}$ is the differential rms voltage signal on channel V2 (volts), V_{ref} is the reference voltage ($2.5V \pm 8\%$) and F_{1-4} is one of four possible frequencies selected by using the S0 and S1 logic inputs (see Table II).

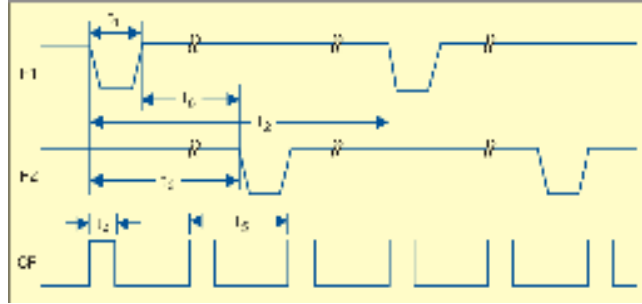

Fig. 5: Output signal timing diagram

S1	S0	F ₁₋₄ (Hz)
0	0	0.85
0	1	1.7
1	0	3.4
1	1	6.8

SCF	S1	S0	CF Signals (Hz)
1	0	0	128×F1, F2
0	0	0	64×F1, F2
1	0	1	64×F1, F2
0	0	1	32×F1, F2
1	1	0	32×F1, F2
0	1	0	16×F1, F2
1	1	1	16×F1, F2
0	1	1	2048×F1, F2

Parameter	Time duration	Units
t ₁	550	ms
t ₂	1.428 (min.)	sec
t ₃	0.714 (min.)	sec
t ₄	180	ms
t ₅	44.65 (min.)	ms
t ₆	165 (min.)	ms

Shunt selection. In order to arrive at the values of $V1_{\text{rms}}$ and $V2_{\text{rms}}$ we must select the size/power dissipation rating of shunt for developing $V1_{\text{rms}}$ (proportional to line current), which is the most critical part of the design. We have chosen the maximum current as 30 amps and the shunt size as given in the application note, i.e., $350 \mu\Omega$. At 30 amps, its power dissipation would

be $30^2 \times 350 \times 10^{-6}$ watts = 315 mW. This is reasonably low.

The chosen shunt must:

1. Provide the necessary dynamic range (400 to 500).
2. Dissipate less power.

3. Be small-size, so that it can be installed within the meter case to avoid tampering.

4. Have low temperature coefficient. (Manganin has low temperature coefficient.)

For experimental purposes, we used 24mm long 18SWG copper wire, which gave a shunt resistance of around $350 \mu\Omega$.

Design example

For designing a meter with 100 pulses/kWh count, proceed as follows:

Step 1. Select the shunt as discussed above. The shunt selected is $350 \mu\Omega$. The sense voltage $V1_{\text{rms}}$ at constant basic current (I_b) of 5 amps would be 1.75 mV.

Step 2. With nominal mains voltage of 230V AC rms and constant basic current (I_b) of 5 amps, the energy consumed in one hour is $230 \times 5 = 1150$ watt-hour or 1.15 kWh.

Since we have selected 100 pulses/kWh, for consumption of 1.15 kWh, the output should be 115 pulses. The equivalent frequency (cycles per sec.) is $115/3600 = 0.0319443$ Hz.

Step 3. Assuming S0 = 0 and S1 = 1, read F_{1-4} value from Table II, which is 3.4 Hz.

Step 4. From the transfer function equation, calculate $V2_{\text{rms}}$ by substituting $V_{\text{ref}} = 2.5V$ and the other values:

$$0.0319443 \text{ Hz} = (515.84 \times 1.75 \times 10^{-3} \times V2_{\text{rms}} \times 3.4) / 2.5^2$$

$$\text{or } V2_{\text{rms}} = 65 \text{ mV}$$

Thus an rms voltage sample of 65 mV measured between V2P and AGND, and V2N and AGND, in conjunction with rms voltage sample of 1.75 mV (refer step 1) measured between V1P and AGND, and V1N and AGND, should produce 115 pulses per

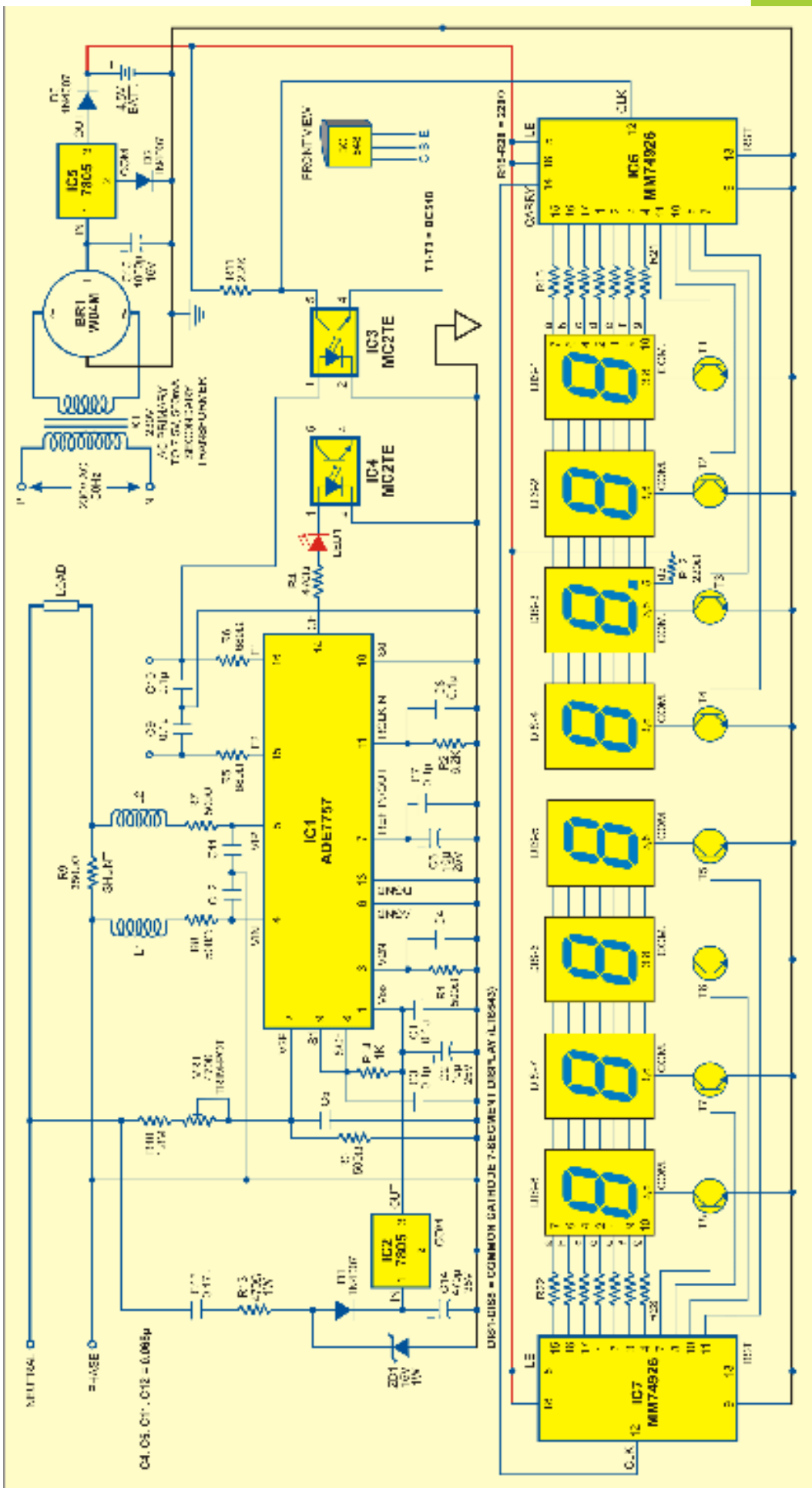

Fig. 6: Circuit of the energy meter using ADE7757

hour, or 0.0319443 Hz (refer Step 2), at F1 and F2 outputs of IC ADE7757. Now, if we set the select calibration frequency (SCF) to logic 1, the output pulses at CF will be 32 times the pulse rate at either F1 or F2 output (see Table III).

As stated earlier, the CF output is used for calibration. Since this frequency is comparatively high, the real power information is accumulated very fast and hence less averaging is carried out for the CF output. That means the meter is more responsive to power fluctuations. The CF output can also be used for interfacing with microcontrollers.

Timing of outputs. The timing diagram for F1, F2 and CF pulse outputs is shown in Fig. 5 and the approximate timings for the selected parameters are given in Table IV.

The circuit

By following the aforementioned design principles, we arrive at the energy meter circuit shown in Fig. 6. IC ADE7757 (IC1) is at the heart of the energy meter. It directly interfaces with the shunt resistor and operates off the AC input. The only analogue circuitry used in IC ADE7757 is in the sigma-delta ADCs

and reference circuit. All the other signal processing is carried out in digital domain.

The power supply for IC ADE7757 is derived directly from mains using the capacitor divider network comprising C13 and C14. Most of the voltage is dropped across C13 (0.47 μ F polyester capacitor rated for 630V), while resistor R13 (470-ohm, 1W) is used as a current limiter. The output across C14 is limited to 15V DC, which serves as an input to regulator 7805 (IC2). The regulated 5V is fed to IC1 at its V_{DD} pin 1. In this application, the phase line is connected to AGND (pin 6) and DGND (pin 13) and hence to the common terminal of regulator IC2.

Two MM74926 ICs (IC6 and IC7) are cascaded to act as an 8-digit ripple counter, in conjunction with eight 7-segment displays (DIS-1 through DIS-8), which require additional 5V regulated and isolated supply (to avoid extension of live mains to the counter section). A conventional 5V regulator circuit incorporating a bridge rectifier (BR1), smoothing capacitor (C15) and regulator IC 7805 (IC5) has been used for the purpose. A 4.5V rechargeable battery is used to provide back-up so that the counter does not reset when mains fails. Diode D3 prevents battery discharge through the regulator during mains interruption. The voltage drop across diode D3 is compensated by using diode D2 in series with the common terminal of regulator 7805 (IC5).

The F1 output of IC1 is coupled to 8-digit ripple counter IC MM74926 via optocoupler IC3, while LED1 indicates that IC1 is working. CMOS IC MM74926 consists of a 4-digit counter, internal output latch, npn output source drivers for the 7-segment display

Soldering of SMT ICs

- Apply flux to the pads where the IC is to be soldered.
- Add a small amount of solder to one of the corner pin pads.
- Line up the IC with the pads on the PCB. Double check the IC orientation.
- Melt the solder with your iron and move the IC into position with tweezers. Let the solder solidify.
- Solder the diagonally opposite pin. Check under magnification that all pins line up with their respective pads.
- Solder the rest of the pins and check under magnification.

Note. Special techniques may be needed for some packages.

(DIS5 through DIS8). IC6 is cascaded to IC7 by connecting the 'Carry' output of IC6 to the clock input of IC7.

Transistors T1 through T8 drive the respective digit displays DIS1 through DIS8.

Since F1 output comprises 100 pulses for each energy unit (kWh), a decimal point is permanently placed between DIS2 and DIS3. Thus the display can show up to 999999.99 units and then restart from 000000.00.

The meter and the PCB layout must be designed such that the conducted/radiated electromagnetic disturbances and the electrostatic discharge do not

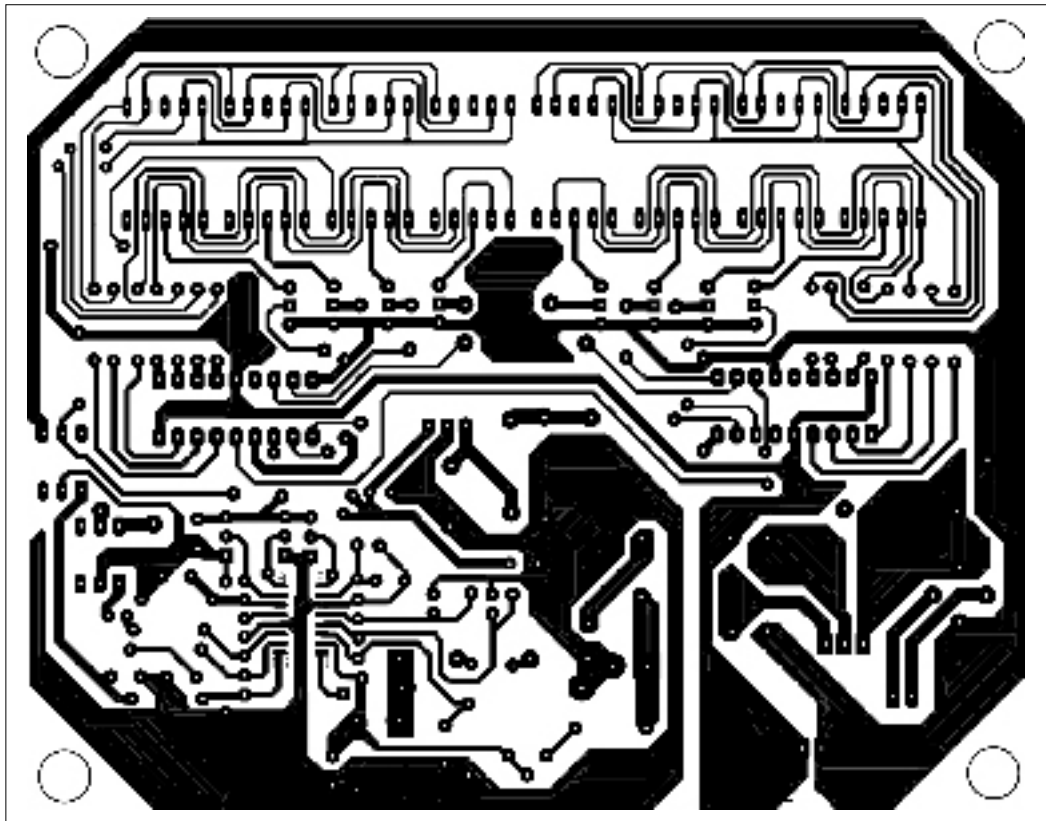

Fig. 7: Actual-size, single-side PCB layout for the energy meter using ADE7757

play and internal multiplexing circuitry with four multiplexed outputs. As multiplexing circuit has its own free-running oscillator, it does not require external clock. The counter advances on the negative edge of the clock pulse. The high input at the latch-enable pin displays the counter outputs.

IC6 drives the first four 7-segment displays (DIS1 through DIS4), while IC7 drives the remaining four displays

damage the meter or disturb its working. Other disturbances to be considered are electromagnetic HF fields, fast transience burst and power line surge.

All of the precautionary components and design techniques (ferrite beads, capacitor line filters, large SMD resistors and grounding of the PCB layout) contribute to protect the meter circuitry from all forms of electromag-

