

8-DIGIT CODE LOCK FOR APPLIANCE SWITCHING



MANEESH CHADHA

This code lock is useful for appliances requiring exclusive or authorised use by those who know the preset code. If desired, the code can be changed.

DIP switches. The code is set using DIP switches DIP3 and DIP4. Then these two switches are hidden inside the assembly. With DIP3 and DIP4, up to 256 code combinations are possible. The unlocking code is set by the user using DIP switches DIP1

T1 conducts.

The codes are compared using two cascaded 4-bit magnitude comparator ICs (IC1 and IC2). If the input nibble present at DIP1 matches with preset DIP3 nibble, output pin 6 of IC1 (connected to

input pin 3 of IC2) goes high. Now if nibble present at DIP2 matches with the preset nibble at DIP4, pin 6 of IC2 also goes high. This high output drives transistor T1 and the appliance turns on via relay contacts.

After use, disturb the positions of DIP1 and DIP2 so that the appliance can't be operated by unauthorised persons. This will also switch the appliance off.

The circuit works off a 5V DC power supply. Hidden switch S0 can be used to manually turn on/off the appliance if you have forgotten the preset code.

Caution. You may use this code lock at your own

and DIP2, which is compared with the preset code entered earlier via DIP3 and DIP4. If the two codes match, transistor

risk. After all, a clever intruder will try all 256 possible combinations one after the other to break the secret code.

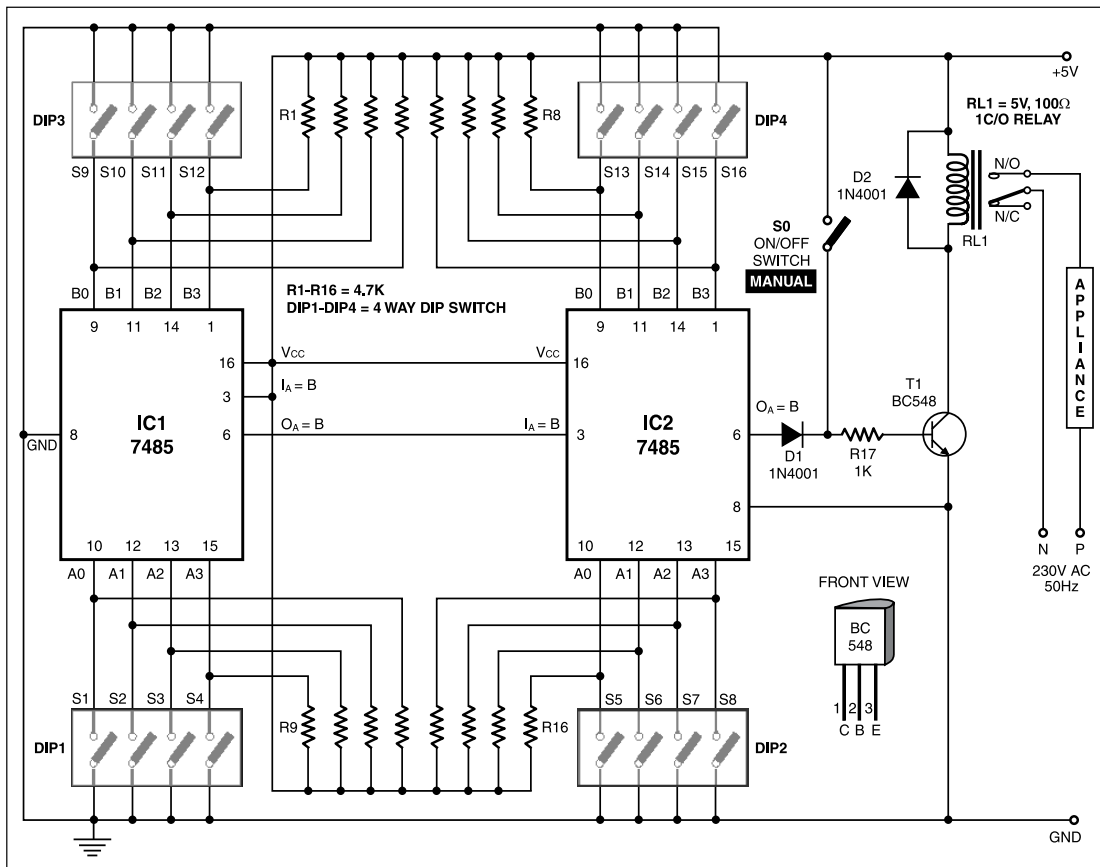

The circuit doesn't require additional AND or NOT gate operations at the outputs. It uses two pairs of 4-way